



## Pilous

Železná 9, 619 00 Brno, Czech Republic

Tel.: +420 543 25 20 10

e-mail: [wood@pilous.cz](mailto:wood@pilous.cz), [www.pilous.cz](http://www.pilous.cz)

### CTR 1000 H 40



5350 x 34-41 x 0,9-1,27  
mm

Max. log diameter	1000 mm
Max. opening between blade guides	850 mm
Max. elevation of blade	875 mm
Min. log height	25 mm
Max. depth of cut	450 mm
Max. log length (standard model)	7,6 m
Length track section	3 m
Min. log length	1,2 m
Saw blade motor	15 (18,5) kW
Horizontal feed motor	1,5 kW
Vertical feed motor	0,55 kW
Hydraulic motor unit	5,5 kW
Hydraulic oil	ISO 6743/4-HM, DIN 51524 part 2-HLP
Sawblade	5350 x 35 ÷ 40 x 0,9 ÷ 1,1 mm
Weight (standard model)	2580 kg
Weight (track section)	420 kg

**Nominal current of circuit breaker is minimally: main el. motor 15,0 kW – 63 Ampere / main el. motor 18,5 kW – 80 Ampere**

## DESCRIPCIÓN DEL PRODUCTO

**Feed into the cut and back - motor-powered**

**Arm height adjustment - motor-powered**

**Control panel - stationary**

**Log handling - hydraulic**

Exceptionally robust construction of the machine and high-performance hydraulic equipment allow operation even under the most difficult operating conditions including non-stop operation. Many hydraulic accessories easily handle even very large logs, significantly increase the productivity of the machine and save labour costs.

The machine is equipped with a measuring system in the basic version with simple intuitive operation on a large colour touch screen. The new generation of the operating system allows a choice of four programming cutting modes. It is possible to set the repetition of a constant or variable thickness of lumber.

It is also possible to choose between two methods of automatic arm exit after the cut, either to a fixed height or by the last measure with an adjustable allowance.

Simple and quick entry of board thickness from an editable library.

The new system guarantees fast and accurate automatic setting of the desired cutting thickness, thus avoiding human error when setting the cut manually. It greatly saves time and makes production more precise.

**The basic version is fitted with following hydraulic accessories:**

- Hydraulic clamp - 2x
- Tilting angle bar - 5x
- Pull-up log turner - 1x
- Log levelling passive roller - 1x
- Log levelling driven roller - 1x

Thanks to the unique modular design of CTR series the machine is fitted with many fitting points for hydraulic equipment. That allows large variability of its placement with regard to the total log length and specifics of the processed material.

A wide, exceptionally massive bridge of the sawmill arm and robust running sections ensure undisturbed operation when cutting and even at high running speeds. Professional execution of all main technical units, such as running wheels with their bearing system, sawmill arm construction, powering and feeding system, etc. ensure maximum service life and machine accuracy even under the most difficult operating conditions.

The central control panel is stationary and it's placed on the main running section. This allows convenient machine control from a single place with complete hydraulic accessories. The feed into the cut and back is driven by an electric motor with worm gearbox controlled by a frequency inverter. The travel speed can be changed simply by turning the potentiometer knob on the control panel. The end positions are secured against impact by automatic deceleration and stopping.

The massive sawmill arm is borne on adjustable hard-chromium rods (for moving up and down) which ensure absolute accuracy of sawmill arm movement and virtually unlimited service life, if the machine is lubricated regularly. The vertical movement of the arm is provided by double-sided synchronous chain transmission powered by an electric motor with worm gearbox.

The arm is fitted with running wheels made of high-quality grey cast iron with accurate balancing against vibrations. The wheel has a groove along its circumference. The groove holds a replaceable rubber-textile flat belt which creates an optimum contact area between the wheel and the sawblade.

The sturdily mounted running wheel is powered through a V-belt by a professional electrical motor specially balanced against vibrations.

The tensioning wheel system moves along a sturdy cast iron dovetail slide with screws and a bar for fine-tuning, which allows highly accurate adjustment without any free travel even in long-term machine operation.

The basis of the machine is formed by extremely stable running sections with reversible, adjustable, steel guidance of the arm bridge. Running sections are amply dimensioned for the indicated maximum diameters of processed logs and based on practice they count even with very tough operating conditions. Double sided guidance of a bridge on the running section combined with a powerful engine, enable fluent and fast shift (removal) of cut pieces when using the Board return arms. The log length is virtually unlimited, it only depends on the number of installed running extending sections. Running sections are fitted with massive, height-adjustable log-bearing beams, tilting angle bars, and log clamps.

The CTR model series represents the latest trends in sawmill design, with special emphasis on maximum accuracy and long service life at minimum cost. The machines are designed in an original modular way, which allows easy replacement or adjustment of all main technical nodes and their individual parts. This significantly reduces maintenance costs in the long-term use of the machine and also reduces service times, thus reducing production downtime.

A wide range of accessories simplify and accelerate machine operation and influence its production. It is therefore possible to adapt the sawmill exactly according to the needs of the customer.

All pictures shown are for illustration purpose only. Actual product may vary due to product enhancement.

# GALERÍA DE IMÁGENES

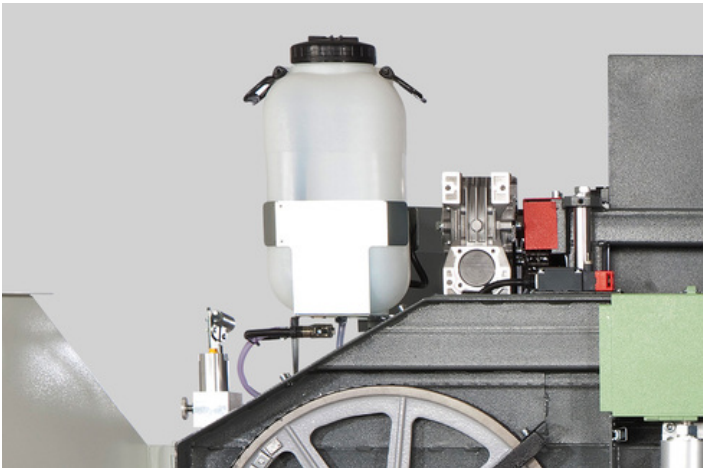
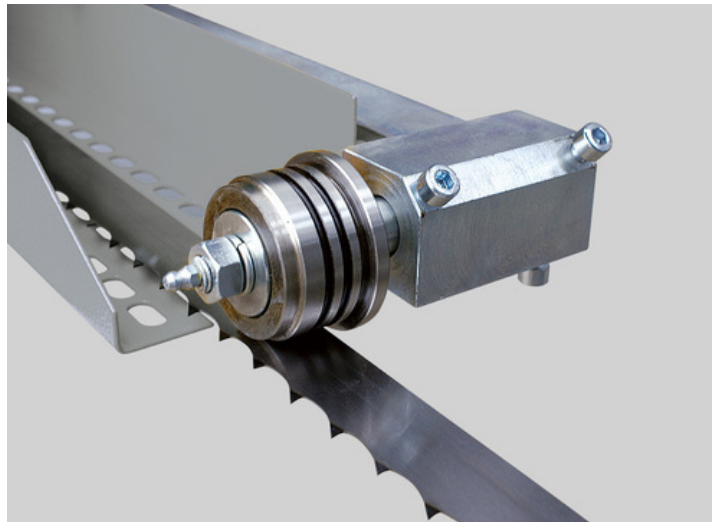
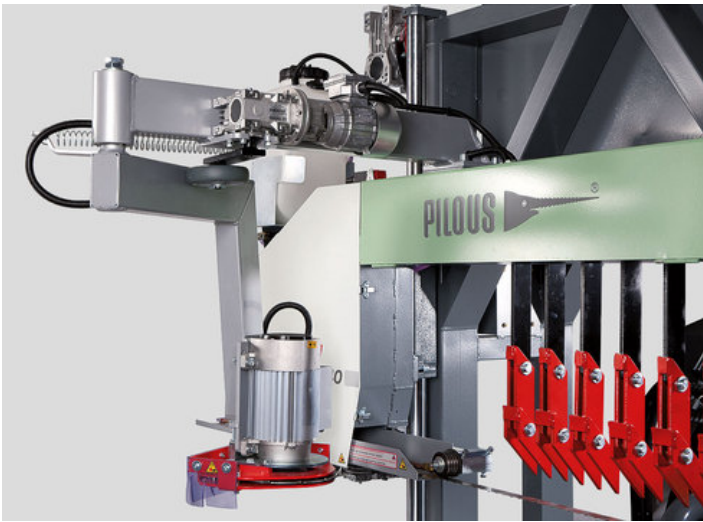
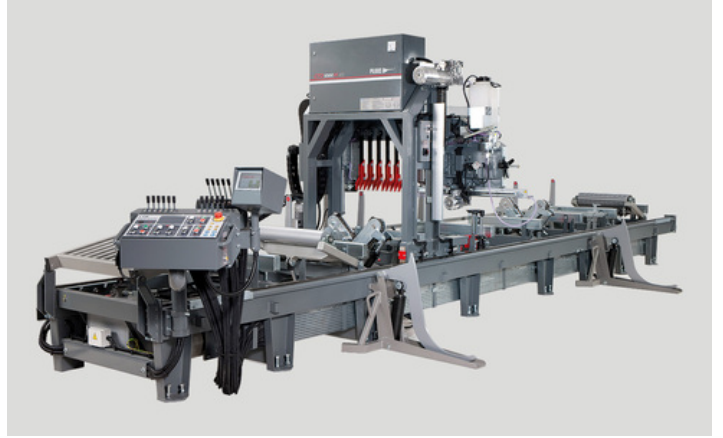



3 m

**Extending section  
3m H**

**Extending section 3 m**

Include 1x Tilting angle bar  
Extending section is equipped with many points for instalation of hydraulic equipment. That provides variability of placement with aspect of cutting material.



1 m

**Extending section  
1m H**

**Extending section 1m**

Include 1x Cross beam.



**Main motor 18.5 kW**

**Main motor 18.5 kW**

For even higher performance, for example, when cutting oversized logs or even when cutting very hard materials, especially with Stellite-tipped blades 18.5 kW motor can be recommended.



**Debarker 1000H40**

**Debarker**

Debarker with hard metal tips is designed to remove dirt at points where the sawmill blade cuts into the log. The saw blade do not get blunt quickly. Frequent saw blade exchanges are reduced, the saw blade life, and the productivity of the machine increase.



**Ammeter - blade  
load indicator**

**Ammeter - blade load indicator**

The ammeter scale shows the saw blade engine load during the cut. It is designed to simplify the selection of the feed speed; it also indicates the saw blade bluntness. A timely exchange of the saw blade increases the life-span and improves the cutting quality.



**Ammeter - digital  
blade load indicator**

**Amperímetro digital**

El amperímetro digital muestra la carga del motor de la sierra de cinta directamente en el panel de control. Sirve como guía para elegir la velocidad de avance en el corte e indica el desgaste de la hoja. Cambiar la hoja a tiempo prolonga su vida útil y mejora la calidad del corte.



**Laser Sight**

**Laser Sight LAS**

Laser aiming is a very practical helper for axial alignment of the log before the cutting. The cutting level shows a line copying the path of the saw blade.



**Cant hook**

**Gancho volteador**

Se utiliza para girar, rodar y manipular troncos. La punta puede usarse para separar troncos o clavarse en el suelo para proporcionar estabilidad durante el trabajo. El gancho volteador se fabrica en longitudes de 79 cm y 125 cm (incluida la punta).



**ARCTIC**

**ARCTIC**

Version of the machine adapted for work in extremely cold operating temperatures reaching down to - 40 °C. Machine's switch board, control panel and digital measuring are fitted with heating elements. The heating is controlled through a thermostat. Frost-resistant lubricant. Band sawmills use frost-resistant hydraulic oil.



**START/STOP  
cooling system**

**START/STOP cooling system**

Integrated in the cooling system is an electromagnetic through-flow valve, which automatically opens when the saw blade is started and closes when the saw blade is stopped. It substantially lowers the coolant consumption and saves time needed for replenishment of coolant liquid.



**Free-standing control panel**

**Panel de control independiente**

Un panel de control independiente con joystick es una opción más cómoda, especialmente en combinación con una silla giratoria. Todo el sistema de control puede integrarse en una cabina, donde no sufrirás del frío durante los meses de invierno.



**Chair**

**Sillón**

La cómoda silla giratoria con cinco opciones de ajuste es el complemento ideal para el panel de control independiente. La silla puede equiparse con calefacción, lo cual es una característica muy solicitada durante los meses de invierno.



**Camera**

**Sistema de cámaras**

El sistema de cámaras HD está diseñado principalmente para vigilar el corte longitudinal en la sierra de cinta y amplía el campo de visión del operario. También puede utilizarse para ajustar el tronco con mayor precisión antes de iniciar el corte. La vista en directo permite controlar el progreso y la calidad del corte en tiempo real y reaccionar rápidamente ante situaciones de colisión si es necesario. El sistema puede ampliarse hasta cuatro cámaras para una mejor visión general y cobertura de las zonas críticas. Se trata de una solución robusta y fiable diseñada para entornos industriales. El monitor no está diseñado para funcionar a temperaturas bajo cero.



**USB**

**USB**

El puerto USB permite cargar la tableta y el teléfono. Ideal si piensas utilizar asistentes de software externos para la planificación de cortes.



**Hydraulic saw blade tensioner 1000H40**

**Hydraulic saw blade tensioner**

Operated by a hydraulic hand pump with accurate pressure indication. The hydraulic saw blade tensioner is more accurate and convenient.



**Soft starter - smooth blade start-up**

**Soft starter - smooth blade start-up**

Electronic device enabling a smooth start-up of the saw blade motor. It prevents grid surges reducing mechanical stress of the whole machine.

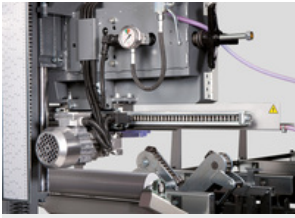

**Electrically controlled guide bar 1000**

**Electrically controlled guide bar**  
Adjustment of sliding guide bar of the saw blade depending on the log diameter electrically controlled from the central control desk.

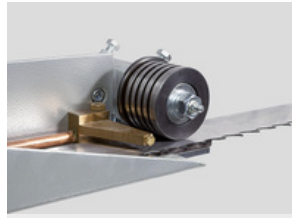

**START/STOP pressure cooling system**

**Double sided START/STOP pressure cooling system**  
The cooling system consists of a pressure pump in the coolant tank, flow control solenoid valve and two-way jets that spray the sawmill blade both from below and from above. Double-side cooling prevents undesirable stress in the saw band and adhesion of resin from underneath the sawmill blade and thus helps maintain stabler sawmill blade operation, more accurate cut and longer service life. Integrated in the cooling system is an electromagnetic through-flow valve, which automatically opens when the saw blade is started and closes when the saw blade is stopped. It substantially lowers the coolant consumption and saves time needed for replenishment of coolant liquid.



**Grease Gun**

**Grease Gun**  
For regular maintenance of the machine according to the lubrication plan. Metal grease gun for 400g tubes. Equipped with a flexible pressure hose.



**Synthetic Grease LV 2-3**

**Synthetic Grease LV 2-3**  
400g tube for the grease gun.

## ACCESORIOS – HYDRAULIC ACCESSORIES

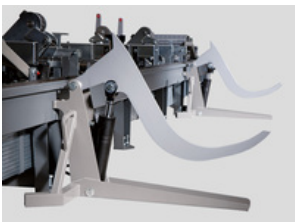

**Double-arm hydraulic log loader 1000**

**Double-arm hydraulic log loader**  
The hydraulic double-arm log loader allows safe and fast lifting of the log onto the loading area of the machine. The main frame of the machine is fitted with lifting attachments along its full length, which allow easy transport of individual holders according to the length of the loaded material. Each loader is controlled separately, which allows to lift easily even very tapered logs.

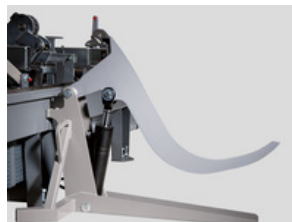

**Additional arm for log loader 1000**

**Additional arm for log loader**



**Pull-up angle bars with hold-down clamps 1000**

**Pull-up angle bars with hold-down clamps**

Comfortable substitution of standard tilting angle bars and clamps. Hydraulic pull-up angle bars and hydraulic hold-down clamps, set of 4 + 2 pieces.

The method of pulling up the hydraulic angle bars eliminates the movement of the log.

Compare with standard clamps the hydraulic hold-down clamps allow the clamping of the log with pressure to the machine bed.



**Hold-down clamp**

**Hold-down clamp**

Hydraulic hold-down clamp align themselves automatically according to the log diameter and allows clamping of the lumber with pressure to the machine bed. All hold-down clamps used on the machine are controlled by a single controller.



**Pull-up log turner 1000**

**Pull-up log turner**

One piece is always a part of the basic version of the machine and it is a vital multi-functional assembly, the most significant of all hydraulic accessories. It moves both in vertical and horizontal axis on strong hard chromium plated rods using two independently controlled hydraulic cylinders. It is used to clamp, turn and feed the material to tilting angle bars.



**Double-arm chain log turner 1000**

**Double-arm chain log turner**

Powerful chain log turner is equipped with two pivoted, separately controlled arms. They hold chains, synchronously driven by a hydraulic motor. The chains facilitate easy turning of the cut material. When cutting long logs that need constant turning we recommend to equip the machine with a pair of turners. This will help reduce the required handling times significantly and therefore increase the machine effectiveness.



**Log levelling passive roller 1000**

**Log levelling passive roller**

Lifts the log axis in horizontal position according to its taper or lifts the whole log above the loading area to allow easier handling. The robust rotary cylinder ensures simple feed of the log.



**Log levelling driven roller 1000**

**Log levelling driven roller**

Lifts the log axis in horizontal position according to its taper or lifts the whole log above the loading area to allow easier handling.



**Hydraulic clamp 1000**

**Hydraulic clamp**

Hydraulic log clamp aligns themselves automatically according to the log diameter or can be locked in the desired position. They are also used for one-side material clamping against Tilting angle bars. All clamps are controlled by a single controller.



**Board return arms**

**Board return arms**

During the back feed of the saw blade arm after the cut the side stops help feed the cut material towards the control panel, allowing very simple collection of the material. From this point the material can be fed onto follow-up belt or roller conveyors.



**Board hydraulic  
slide 1000**

**Board hydraulic slide**

The hydraulics allow setting in accordance to the cutting plane. It is used to slide the fed material onto the follow-up belt or roller conveyors.

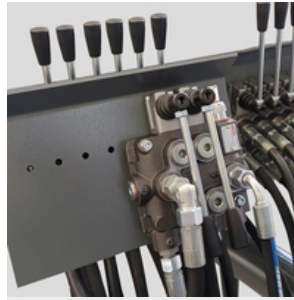

**Hydraulic lever**

**Hydraulic lever**

The additional lever of the hydraulic distributor enables the connection and control of additional hydraulic accessories.

**ACCESORIOS – CONSUMABLE PARTS**

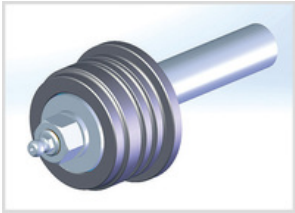

**Blade Roller Kit VK  
35**

**Blade Roller Kit VK 35**

Hardened roller, bearings, and shaft designed for a sawmill blade 35 mm.

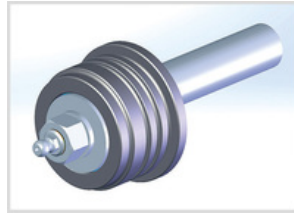

**Blade Roller Kit VK  
40**

**Blade Roller Kit VK 40**

Hardened roller, bearings, and shaft designed for a sawmill blade 40 mm.

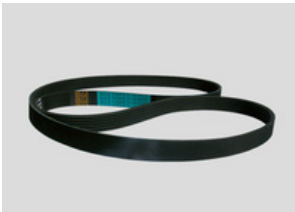

**Wheel Flat Belt GPK  
1885**

**Flat running wheel belt GPK 1885**

# MAXWOOD

- The original sawmill blades PILOUS MAXwood are available in a variety of types which enables you to process any kind of wood.
- The wide product range not only offers more affordable sawmill blades for low-volume cutting, but includes also sawmill blades for fully professional cutting and utmost performance.
- The foundation of all sawmill blades are top-quality German materials and precise workmanship. The quality of the sawmill blades is carefully monitored. All sawmill blades correspond to the strict ISO 9001 norm.
- We have added to our portfolio also an original Munkfors sawmill blade made by the world's leading manufacturer Uddeholm from Sweden.
- Pilous sawmill blades are used in dozens of countries around the world. Any wood you cut, the company Pilous will recommend you a sawmill blade that will fit your needs.

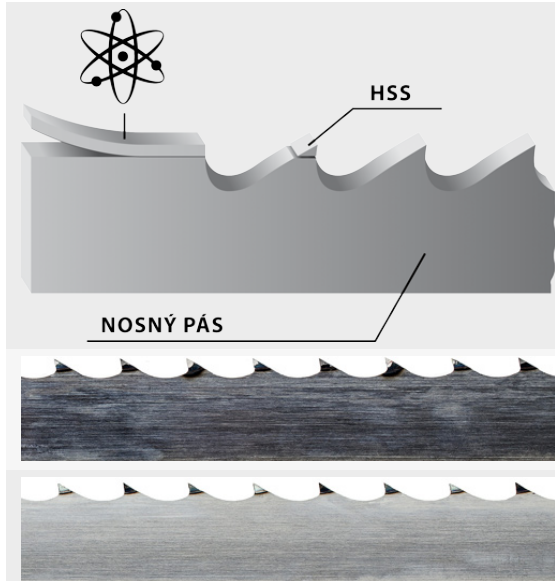

## BiMetal

Sawmill blade with tool steel teeth - completely eliminates the need to sharpen the sawmill blade as well as frequent blade replacement. Use: soft, hard to extremely hard wood.

## HSS

Bearing blade

## Stellite

Sawmill blade with teeth made of Stellite. Tooth setting is completely unnecessary. Use: soft, hard to extremely hard wood.

## Carbon / Chrom-Vanadium spring steel

The most common sawmill blade for optimum price/performance ratio. Use: soft and hard wood.



Be careful when unpacking welded sawmill blades. They are in a shipping container in tensioned condition. Remove the sawmill blade cover only after fitting it onto the machine.

